

SIDE CHANNEL BLOWERS

BX 093 001 – Single Impeller – IE2



Construction of the ring blowers fans is based on the lateral ducts principle. The blowers can operate as either exhaust or compression fans and are designed for continuous service. The device is assembled directly on the motor shaft; all the rotating parts are dynamically balanced to ensure absolute absence of vibration. Full die-cast aluminum construction for maximum sturdiness and ease of handling. The characteristics data given here refer to the handling of gas with inlet temperature of 15°C, normal density of 1,23 kg/m³ and absolute pressure of 1023 mbar. Tolerance of ±10%. Max gas inlet temperature 40°.

Model	Freq. [Hz]	Power [kW]	Voltage [V]		Rated Current [A]		Max Airflow [m ³ /h]	Rated VACUUM [mbar]	Rated COMPRESSOR [mbar]	Noise [dB A]	Weight [kg]
			△	Y	△	Y					
BX093 001 085 00	50	8.5	345+415	600+720	18.2	10.5	1370	-120	110	75	98
	60	9.8	380+480	660+720			1650	-140	140	80	
BX093 001 125 00	50	12.5	345+415	600+720	28.0	16.2	1370	-190	180	75	121
	60	14.5	380+480	660+720	29.0	22.5	1650	-150	150	80	
BX093 001 185 00	50	18.5	345+415	600+720	37.0	21.0	1370	-310	320	75	131
	60	21.3	380+480	660+720	39.0	22.5	1650	-300	280	80	

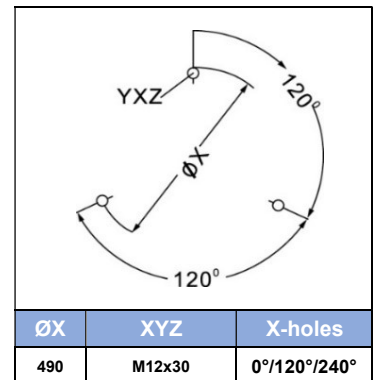
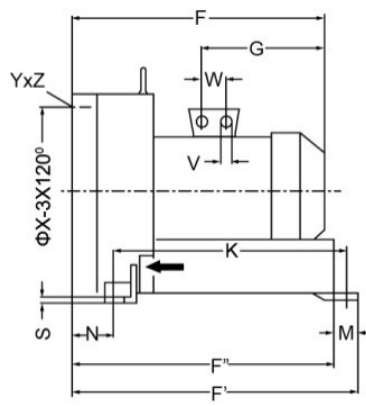
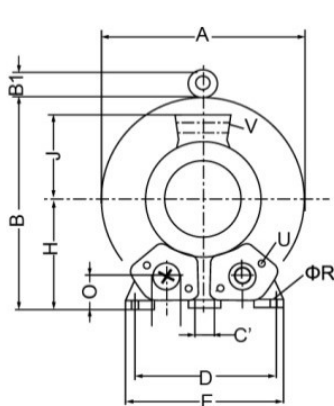
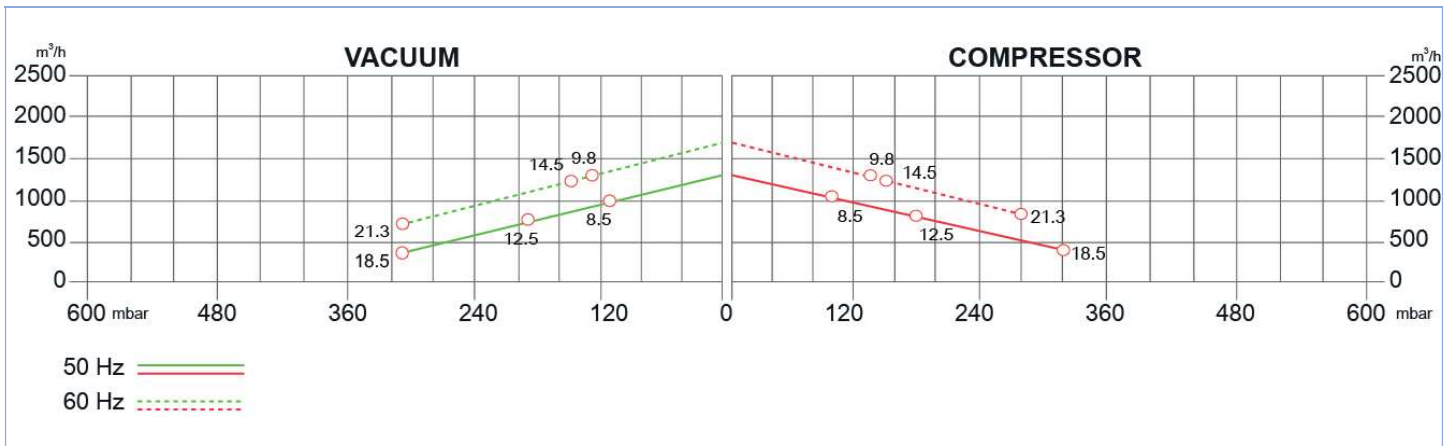

MODEL	A	B	B ₁	C	C'	D	E	F	F'	F''	G	H	J	K	M	N	O	ØP	Q	ØR	S	U	V	W
BX093 001 085 00								563			268													42
BX093 001 125 00	550	569	55	207	15	360	415	649	682	643	345	300	167	533	39	127	92	G4"	150	15	21	M12x30	4XM32X1.5	54
BX093 001 185 00																								

SIDE CHANNEL BLOWERS

BX 093 001 – Single Impeller – IE2

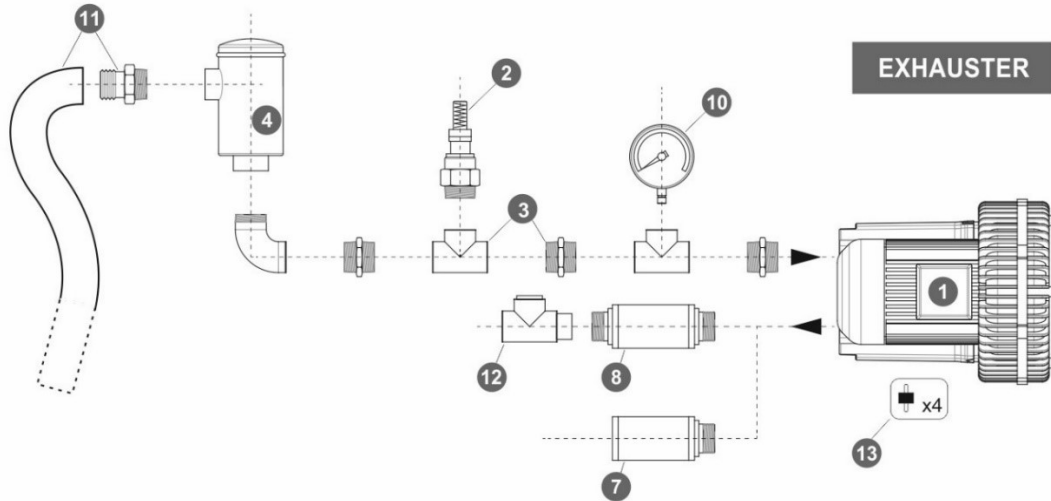

Ref. #	Description	Code
1	Side Channel Blower – Single Impeller / Single Stage – Ø4" connection	BX 093 001__
2	Safety Valve	BXSV100AL02 BXSV100AL46
3	Installation kit safety valve	BXKS100100C BXKS10F100C
4	In-Line filter	Paper Polyester Stainless Steel 30 µ Stainless Steel 60 µ
5	Cartridge filter	BXCF100PA007
6	Filter kit	Nipple Socket
7	Final Silencer	BXFS100ZP – BXFS100ZPR
8	In-Line silencer	BXIS100
9	Indoor filter	-
10	Gauge	Pressure Vacuum
11	Sleeve + Hose clip kit	BXSH100
12	Check valve	BXCV100AL
13	Anti-vibration pins	BXAV12

